

Gas Machine Gun

.22 Caliber Fully and Semi Automatic
Airgun Prototype
Instruction manual

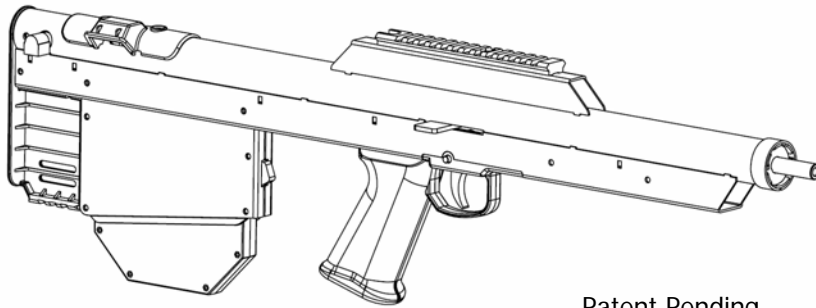

Patent Pending

- Airgun Parts
- Safety Operation
- Loading the Shell Casings
- Loading the Magazine
- Preparing to Shoot
- Shooting the Airgun
- Clearing the Airgun
- Other Operation and Maintenance

! WARNING !

- This airgun is not a toy and is intended for use by adults over the age of 18.
- Misuse can cause injury and death. This airgun is harmful to 300 yards.
- You are responsible for learning and obeying all laws and regulations in your area regarding this product.
- This airgun uses lead pellets. Lead is dangerous. Wash your hands after handling.
- Never leave this airgun unattended. Keep the safety engaged when not in use, and store it un-loaded and un-cocked.
- Always keep airgun out of reach of children and adults unfamiliar with proper operation.
- Always wear eye protection while using.
- Do not disassemble the magazine. Components are under high spring forces and may cause injury.
- **NEVER discharge or aim this airgun at another human body.**

! CAUTION !

Do not disassemble or modify the GMG airgun prototype.

Airgun Parts

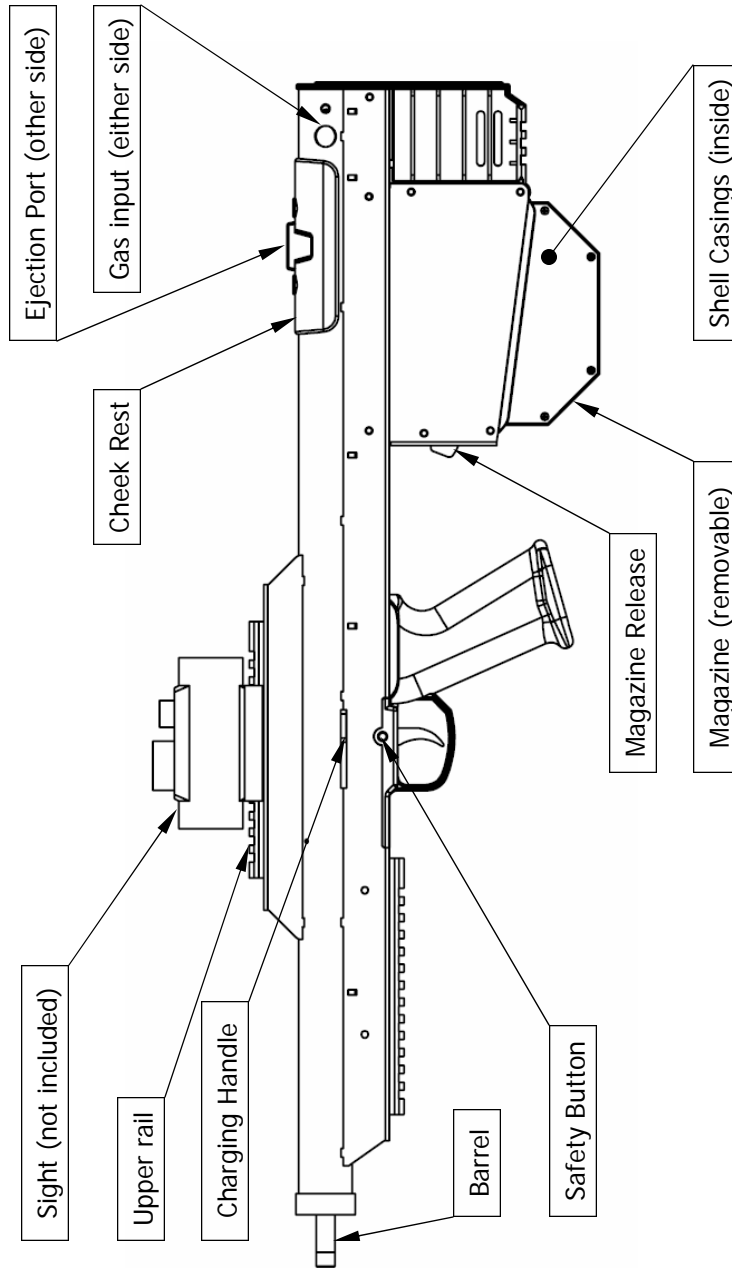

Safety Operation

SAFETY ON

To engage the trigger lock, press the safety button to hide the red ring. Because the airgun can be setup ambidextrously, this could be on either side of the airgun.



SAFETY OFF

To disengage the trigger lock, press the safety button to show the red ring. Because the airgun can be setup ambidextrously, this could be on either side of the airgun.



RED SHOWING = READY TO FIRE
RED NOT SHOWING = SAFETY ON

! WARNING !

- Always keep the airgun ON SAFE when handling.
- Always point the airgun in a safe direction.
- Keep your airgun un-cocked and ON SAFE until ready to fire.

Loading the Shell Casings

LOAD SHELL CASINGS

Set shell casings on end and press one projectile into each shell casing. Use a pencil eraser or the butt of a Sharpie marker to 'sink' the projectile into the shell. Pellets can point toward either side of the casing.

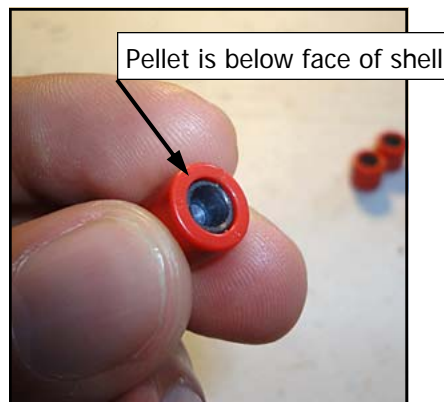

! CAUTION !

- Make sure the projectile is below the surface of the shell casing or it will jam inside your magazine.
- The projectile must fit snugly inside the shell casing. **DO NOT USE PROJECTILES WHICH EASILY SLIDE OUT OF THE SHELL CASING.** Loose projectiles will jam inside your magazine.

! WARNING !

Lead is harmful. Clean your hands after handling lead

Loading the Magazine

ORIENT MAGAZINE

Take note which side of the magazine is the 'front' and make sure you orient each projectile pointed forward as you load it into the magazine.



! CAUTION !

Do not load empty shell casings. They will not operate the airgun and may damage your magazine when they jam.

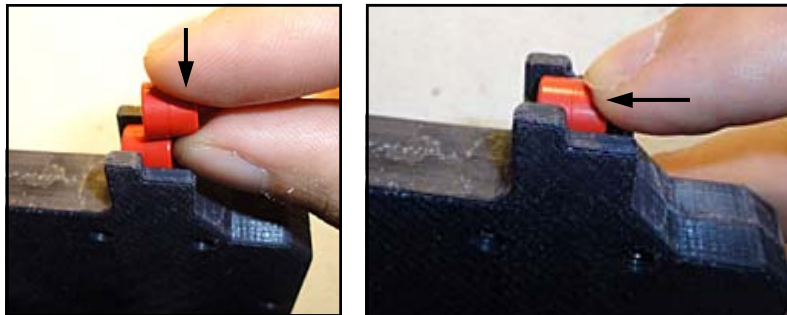

LOAD MAGAZINE

Take each shell casing and press down on the exposed portion of the previous shell casing in the magazine and then slide it forward under the magazine feed lips.

REPEAT UNTIL FULL

Continue adding loaded shell casings until the white follower is visible in the viewing hole. This will be 50 shells.

! CAUTION !

Do not try to load more than 50 shells into your magazine

Preparing to Shoot

ENGAGE SAFETY

As described in first section

CHARGE AIRGUN

Push charging lever FORWARD until it clicks. Release charging lever.



INSTALL MAGAZINE

Correctly orient the magazine (feed lips closer to the butt stock) and insert the magazine into airgun. Push lightly up on the bottom of the magazine until the magazine release button clicks. The magazine will be locked in place.

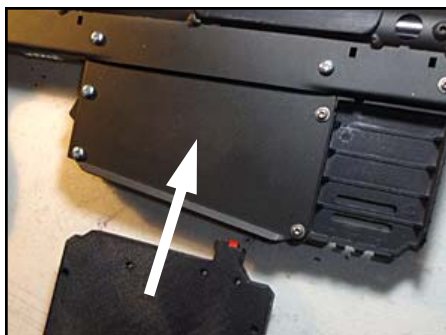

! CAUTION !

- Make certain the magazine is correctly oriented or the feed lips will be damaged upon installation into the airgun.
- Do not try to install a loaded magazine into the airgun without first charging the airgun. This may damage your magazine or airgun.

Preparing to Shoot (continued)

CONNECT GAS LINE

Attach gas line to the GMG in accordance with the instructions that came with your gas line. Point the airgun in a safe direction and turn on the gas supply.

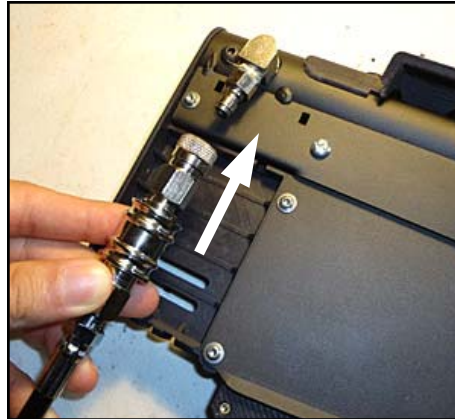

THE AIRGUN IS READY TO USE

Shooting the Airgun

1. Select your target.

! WARNING !

NEVER aim or shoot this airgun at a human body including yourself

2. Assure the area behind the target is safe.
3. Aim using the sight you installed on the upper accessory rail.
4. Disengage your safety using the safety button.
5. Squeeze the trigger half-way for a single shot.



6. Squeeze the trigger fully to engage fully-automatic firing.



7. Use short bursts of full auto for better control and to conserve ammo.
8. Engage safety button when done shooting.

Clearing (making safe) the Airgun

1. Press the mag release button and remove magazine from airgun.
2. Push charging handle forward until it stops and keep light forward pressure on the lever.
3. Point airgun in a safe direction.
4. Depress trigger and keep forward pressure on the charging lever slowly moving it rearward until at rest. The airgun is discharged.

! CAUTION !

NEVER dry-fire your airgun. Always discharge the GMG in the manner described here. Charging and firing the airgun without gas pressure and a properly loaded magazine can damage your airgun.

5. Engage safety with safety button.
6. Use slide-check valve (if applicable) to release pressure from gas line.
7. Un couple gas line quick-connect from airgun.
8. The airgun is cleared.

! CAUTION !

Do not try to discharge (de-cock) a charged airgun with a loaded magazine installed. This will jam a shell casing into your airgun. Remove the magazine before discharging the airgun.

Other Operation and Maintenance

AMBIDEXTROUS PARTS

The GMG is completely ambidextrous, so all pertinent parts can be re-assembled for left or right hand users. The process is a bit more involved than the scope of this manual allows, so please email us for assistance.

STORAGE

Always clear your GMG and unload your magazines before storing the airgun. This will prevent long-term spring set.

LUBRICATION

Oil your GMG once a month with a light gun oil (Rem Oil is great) at the places noted below. Oil more frequently if the GMG is in a humid or wet environment. Do not use WD-40 or other solvent based products.

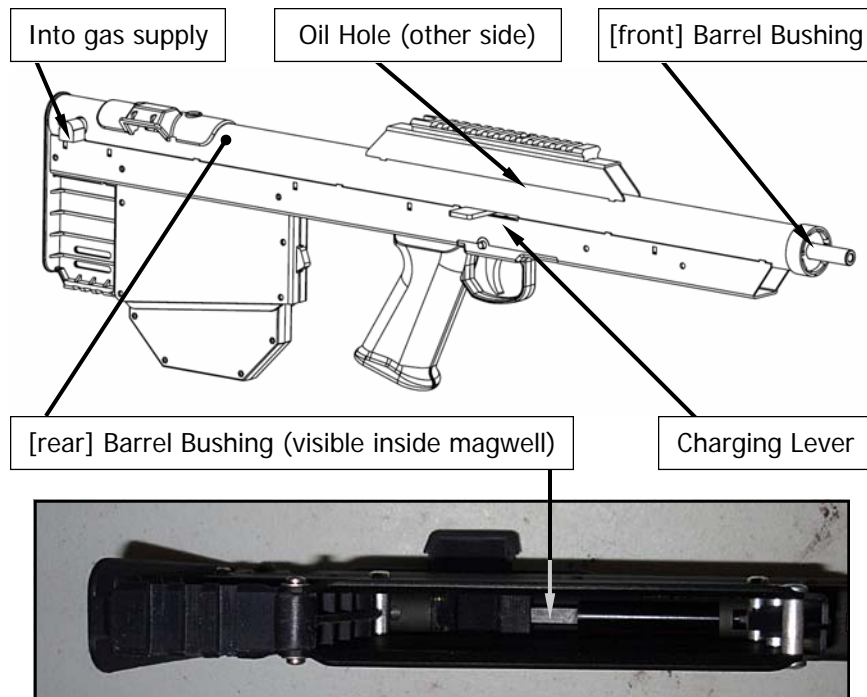

! CAUTION !

Do not lubricate your magazine. It will cause binding.

! WARNING !

- This prototype airgun is not a toy and is intended for use by adults over the age of 18.
- Misuse can cause injury and death. This airgun is harmful beyond 300 yards.
- You are responsible for learning and obeying all laws and regulations in your area regarding this product.
- This airgun uses lead pellets. Lead is dangerous. Wash your hands after handling.
- Never leave this airgun unattended. Keep the safety engaged when not in use, and store it un-loaded and un-cocked.
- Always keep airgun out of reach of children and adults unfamiliar with proper operation.
- Always wear eye protection while using.
- Do not disassemble the magazine. Components are under high spring forces and may cause injury.
- **NEVER discharge or aim this airgun at another human body.**

! CAUTION !

Do not disassemble or modify the GMG airgun prototype.

revision 11.11.19

fullyautomaticairgun.com

All content Copyright 2011